



Simonini

RACING

MINI 2 PLUS



This manual aims to inform you of the main technical, functional and maintenance specifications of your MINI 2 PLUS engine. Read the following pages carefully and you will be able to ensure the safety, reliability and good, long-lasting satisfaction of the engine. This manual is considered an integral part of the MINI 2 PLUS engine and in the case of transfer it must be handed over to the new owner.

All the information available at the time of going to print is shown in this manual. SIMONINI S.r.l. in any case reserves the right to make modifications or changes without prior notice.



MINI 2 PLUS

owner's manual

TECHNICAL DATA

BORE 66,4mm

STROKE 58mm

DISPLACEMENT 202 cc

COMPRESSION RATIO 10,5/1

Weight ready to fly 18,300 kg

CONSUMPTION AT 5000RPM 2,5litres/hour

POWER 7500RPM 26hp

STATIC THRUST Over 80Kg

Lamellar intake with Walbro Carburetor WB37

Aluminum cylinder with ceramic coating magnesium,

Exhaust resonance

Poly-V belt reduction

Electronic ignition

Electric starter

Alternator battery charger in flight

Lubrication premix: 2.5% with premium-grade gasoline

3.0% with unleaded fuel

REDUCTION RATIO AVAIABLE

1:226 Crown gear 129 mm / Pinion 57mm

1:230 Crown gear 129 mm / Pinion 56 mm

1:234 Crown gear 129 mm / Pinion 55 mm

1:242 Crown gear 129 mm / Pinion 53 mm

1:3 Crown gear 138 mm / Pinion 44 mm

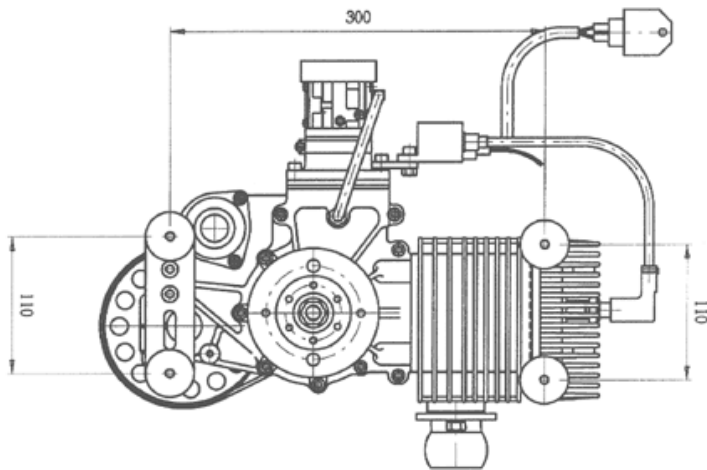
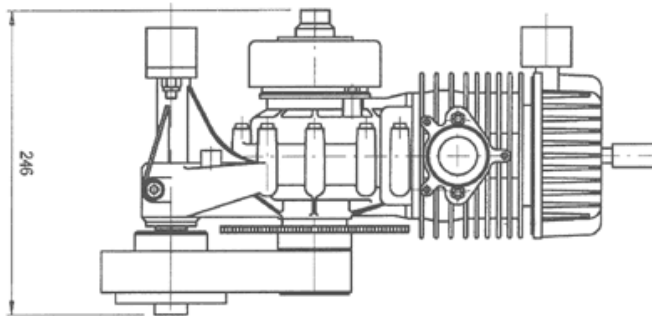
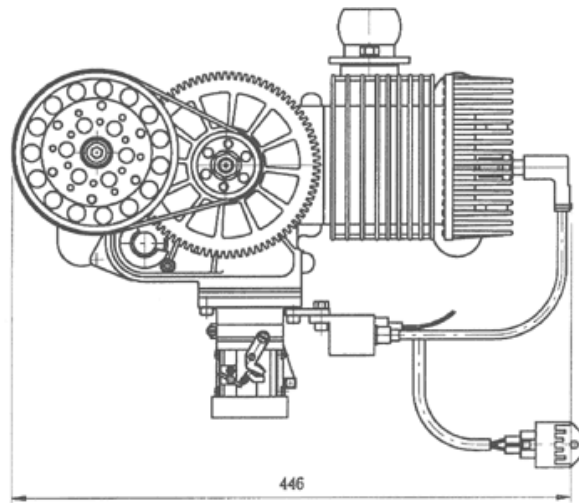

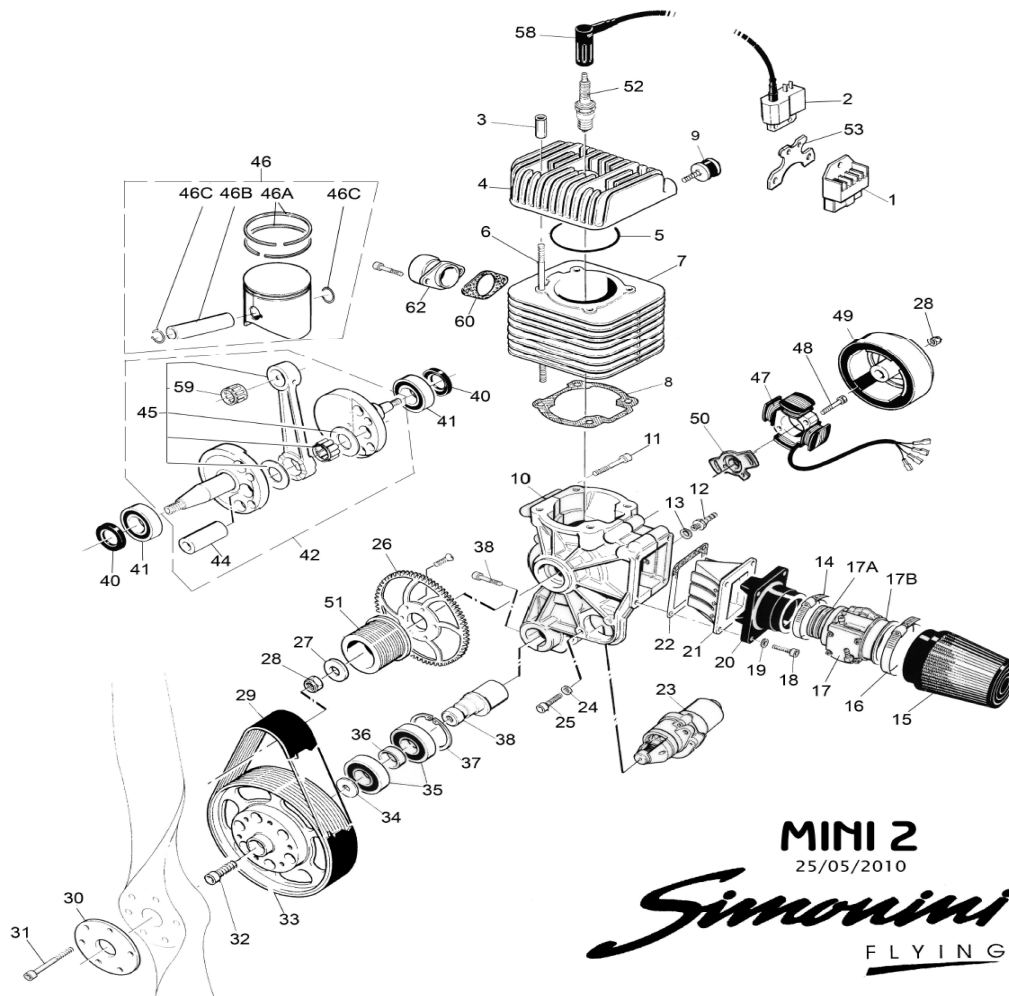

| | | | |
|-----------------|-------------------------------|---------------|--|
| MINI2PLUS/01 | RECTIFIER RE-CHARGE BATTERY | MINI2PLUS/36 | BEARINGS SPACER |
| MINI2PLUS/02 | COIL | MINI2PLUS/37 | PULLEY SEEGER |
| MINI2PLUS/03 | KIT SCREWS FOR HEAD (4) | MINI2PLUS/38 | ECCENTRIC PINION |
| MINI2PLUS/04 | CYLINDER HEAD | MINI2PLUS/40 | KIT SEALS (2) |
| MINI2PLUS/05 | CYLINDER HEAD GASKET | MINI2PLUS/41 | KIT BEARINGS FOR CRANKCASE (2) |
| MINI2PLUS/06 | KIT SCREWS FOR CYLINDER (4) | | OLD TYPE 4304-6304/C3 - NEW 4205-6205/C3 |
| MINI2PLUS/07 | CYLINDER | MINI2PLUS/42 | COMPLETE CRANKSHAFT AND ROD |
| MINI2PLUS/08 | CYLINDER GASKET | MINI2PLUS/45A | COMPLETE CONNECTING ROD (new type 22mm) |
| MINI2PLUS/09 | KIT SILENT-BLOCKS (4) | MINI2PLUS/46 | COMPLETE PISTON AND RINGS |
| MINI2PLUS/10 | CRANK CASE | MINI2PLUS/46A | TWO RINGS |
| MINI2PLUS/11 | KIT ENGINE SCREWS | MINI2PLUS/46B | PISTON PIN |
| MINI2PLUS/12 | WASHER-PRESSURE OUTLET | MINI2PLUS/46C | SET PISTON CIRC CLIP |
| MINI2PLUS/15 | AIR FILTER | MINI2PLUS/47 | STATOR |
| MINI2PLUS/17 | CARBURETTOR WALBRO WB 37 | MINI2PLUS/49 | FLY- WHEEL |
| MINI2PLUS/17A | ALUMINIUM MANIFOLD | MINI2PLUS/50 | ALUMINIUM PLATE FOR STATOR |
| MINI2PLUS/17B | PLASTIC MANIFOLD | MINI2PLUS/51 | LITTLE PINION FOR REDUCTION |
| MINI2PLUS/17C | PAPER GASKET FOR CARBURETOR | MINI2PLUS/52 | SPARK PLUG BR 10 ES |
| MINI2PLUS/17D | ALUM. MANIFOLD FOR AIR FILTER | MINI2PLUS/53 | ALUMINIUM PLATE FOR COIL |
| MINI2PLUS/20 | CARBURETTOR RUBBER MANIFOLD | MINI2PLUS/54 | EXHAUST SYSTEM |
| MINI2PLUS/21 | REED VALVE | MINI2PLUS/54A | EXHAUST BEND |
| MINI2PLUS/22 | REED VALVE GASKET | MINI2PLUS/54B | SILENCER |
| MINI2PLUS/23SIL | ELECTRIC STARTER SILVER | MINI2PLUS/54C | INOX/SILICON CLAMP |
| MINI2PLUS/23GOL | ELECTRIC STARTER GOLD | MINI2PLUS/54D | EXHAUST CHAMBER |
| MINI2PLUS/26SIL | CROWN GEAR SILVER | MINI2PLUS/55 | ALUMINIUM PLATE FOR SILENT-BLOCK |
| MINI2PLUS/26GOL | CROWN GEAR GOLD | MINI2PLUS/58 | RUBBER FOR SPARK PLUG |
| MINI2PLUS/27 | WASHER FOR PINION | MINI2PLUS/59 | CONNECTING ROD CAGE |
| MINI2PLUS/28 | NUT FOR PINION AND FLY-WHEEL | MINI2PLUS/60 | EXHAUST GASKET |
| MINI2PLUS/29 | POLY- V BELT | MINI2PLUS/61 | COMPLETE GASKET KIT |
| MINI2PLUS/30 | ALUM. PLATE FOR PROP. +SCREWS | MINI2PLUS/62 | EXHAUST MANIFOLD AND SPRINGS |
| MINI2PLUS/32 | SCREW FOR BIG PULLEY | MINI2PLUS/63 | KIT MEMBRANE WALBRO WB32/37 |
| MINI2PLUS/33 | BIG PULLEY | MINI2PLUS/64 | LITTLE WHITE MEMBRANE WB32/37 |
| MINI2PLUS/33A | BIG PULLEY for 1:3 | MINI2PLUS/65 | REED VALVE PETAL |
| MINI2PLUS/34 | PULLEY SPACER | | |

TIGHTENING TORQUES

| Description | Special number in table | NM | Kgf.m |
|--------------|-------------------------|----|-------|
| Head Nut | 3 | 22 | 2.2 |
| 6x40 Screws | 11 | 12 | 1.2 |
| Connector | 12 | 10 | 1.0 |
| 6x30 Screws | 18 | 12 | 1.2 |
| 6x25 Screws | 25 | 10 | 1.0 |
| 12 Nuts | 28 | 54 | 5.4 |
| 12x30 Screws | 32 | 60 | 6.0 |
| 8x40 | 39 | 24 | 2.4 |
| Spark Plug | 52 | 18 | 1.8 |

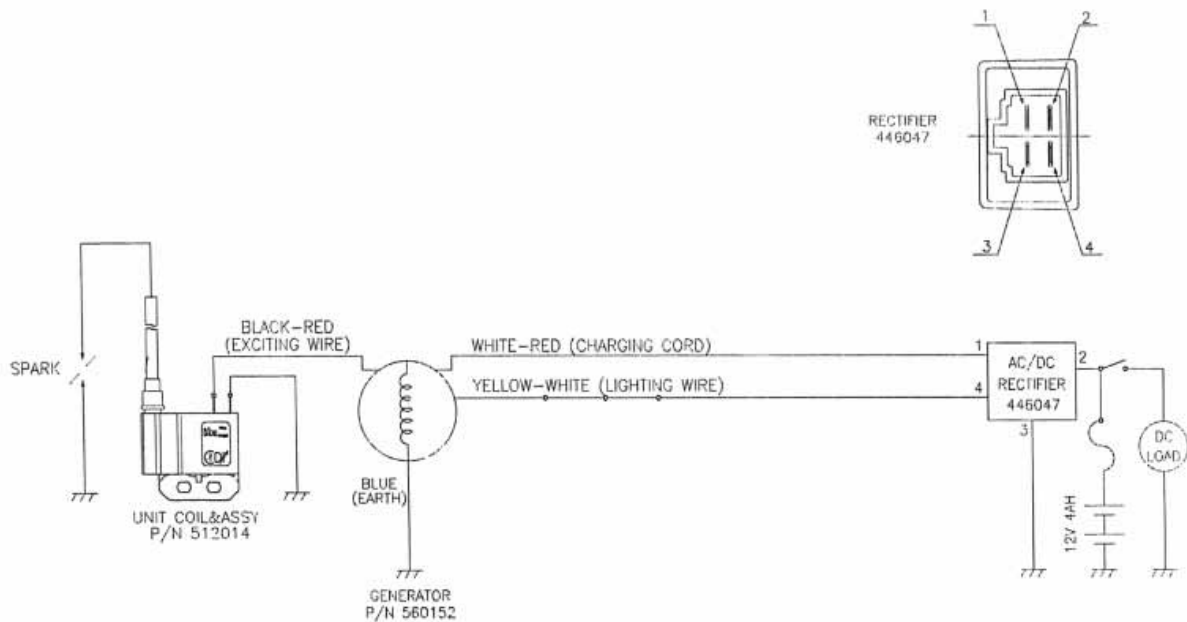

The MINI 2 PLUS engine must be fitted to the frame using its four elastic supports "silent blocks", radial mounted: two are positioned on the head and two on the blue ergal plate.

During the installation, some safety precautions must be made: remember that an engine generates vibrations, even if very few, which can cause the loosening and/or removal of screws or any other object. Therefore, to prevent any engine components may cause damage to persons and/or property, make sure the engine through a small steel cable. Components normally "made safe" are:

- The filter and the carburetor to the engine
- The springs and exhaust to the engine
- The engine itself to the frame, bypassing the silent blocks. In this case we will use the "webbing" of synthetic fiber is particularly resistant to traction and tearing.

The spherical mouth of the muffler should be lubricated with grease resistant to high temperatures (e.g. copper grease) before being implanted in the exhaust manifold.

We recommend taking maximum care when carrying out these operations: in any case, during the assembly phase the proper choices must be made by expert and qualified personnel.

FUEL

The MINI 2 PLUS engine is designed to operate with a gasoline/oil mixture.

We recommend using a semi-synthetic oil (for example, BARDAHL VBA SYNT) that, although inferior to a pure synthetic, remains mixed with gasoline in the tank for a longer period.

During the running-in stage, use an oil percentage of 3,5% and then move to 3% once the stage has been completed.

The gasoline must have an octane number not lower than 95, in order to avoid pre-ignition phenomena.

Carefully mix the fuel oil in a tank is appropriate and it is better, once mixed, to use it within one week. Do not use vegetable or animal oil.

DO NOT MIX DIFFERENT TYPES OF OIL. We do never recommend using Castrol TTS Oil. None guarantees by using this oil will be applied.

CARBURETOR

The carburetor Walbro WB37, if used properly, provides excellent performance requiring few tuning interventions. However, changes in weather conditions, altitude and a possible change of the propeller (both in size and in pitch) can affect its functioning.

The carburetor is adjusted during the testing phase with a standard setting

- Screw H "affects the entire range of use of the engine". From completely tightened, loosen by 1 + ¼ turn or 450°.
- Screw L "only has an effect at a low engine speed". From completely tightened, loosen by ¾ turn or "270 °".

Since the first test is performed at an altitude of 600 m above sea level, you may need to depart from this setting without the adjustments exceed the limit:

- screw-H do not fall below a round "360 °"
- Screw L do not fall below ½ turn "180 °"

The carburetor is equipped with a depression pump to remove fuel from the tank, but do not exceed the height difference between them as it has not exceed to 50-60cm. The same applies to the tube: do not exceed 50-60cm.

CARBURATION

NB: in this paragraph the words "MIXTURE" indicates the union of the two elements (AIR) + (OIL/GASOLINE) which takes place inside the carburetor.

Weather conditions or altitude changes have influence to the operation of the engine as it varies the air density and, consequently, changes the mix ratio between the element AIR and the element OIL /GASOLINE.

In general, we can state that at high altitude, high humidity or high temperatures, less air enters and therefore the mixture is richer in oil/gasoline: you will have to re-establish the proper relationship by screwing the two screws "H/L".

In contrast, with low temperatures and low humidity, the air will become denser so

a lean carburetion requires you to unscrew the two screws "H / L".

WARNING: A mixture that is too low in oil/gasoline causes considerable damage to the engine that can cause a break down and/or stop it suddenly. It is recommended to carry out the carburetion operations with the ENGINE SWITCHED OFF. When the "H / L" screws are tightened/loosened, carry out variations of 1/8 of a turn each time or "45°", larger movements in a turn can cause engine damage.

RUNNING-IN

WARNING

- Before starting the engine, make sure that there are no loosened screws or improperly attached parts;
- Ensure that any person is at a distance of absolute safety and never in the range of the propeller;
- Do not start the engine where there are rocks or any objects that the force generated by the propeller can lift and throw even at a considerable distance;
- Do not start the engine without the propeller nor the exhaust;
- Do not start the engine indoors: the exhaust gases contain poisonous carbon monoxide which are toxic and can cause loss of consciousness and death.

The engine, before being sold, is subjected to a pre-running-in to verify the proper operation and a test that confirms all the features advertised.

Once you order a MINI 2 PLUS, you should pay particular attention to the first hour of operation, in order to ensure all the engine's qualities over time.

DURING THE RUNNING-IN PHASE, KEEP PARTICULAR ATTENTION TO THE EXHAUST GAS TEMPERATURE AND HEAD TEMPERATURE UNDER CONTINUOUS OBSERVATION.

Having selected a suitable place and above all free from gravel or other materials that may damage the moving parts, start the engine and let it warm up for 10 minutes at 2500 rpm, then slowly bring the engine to a system more high, decreasing and increasing the speed at intervals of 1 minute, thus going to affect various "range" of use, but without exceeding 4500 rpm. Absolutely avoid the constant and repeated closing/opening the gas valve. After about 20 minutes from start-up, shut down the engine and let cool completely.

WARNING! When the engine is running and even after its shutdown, it can cause

burns: so make sure it is completely cooled before working on it.

Proceed with a thorough visual inspection of any anomalies or loose parts. Once you make sure everything is working properly and there are no problems of any kind, you must repeat the previous operation for another 20 minutes of running, respecting the same indications.

Last running-in phase: warm up the engine again for 10 minutes at 2500RPM and then, as in the two previous operations, gradually increasing the RPM. Now you can wander over the entire range of use of the engine, bringing it several times to the maximum speed at intervals of 1 minute.

After 20 minutes you can turn off the engine and, once cooled, you will proceed to a full-tightening the screws on the MINI 2PLUS. Now the engine MINI 2 PLUS will be ready for use for which it was designed by continuing to use a percentage of oil by 3% for the next 10 hours.

WARNING! DURING THE RUNNING-IN PHASE, KEEP PARTICULAR ATTENTION TO THE EXHAUST GAS TEMPERATURE AND HEAD TEMPERATURE UNDER CONTINUOUS OBSERVATION.

MAINTENANCE

Each time you use the engine, remember to perform routine checks pre-start-up:

- Check the silent block condition in complete integrity
- Make sure the exhaust does not present any cracks
- Ensure that the propeller does not present cracks or dents
- Make sure you have enough fuel, according to the duration of intended use of the engine.
- Check that the electrical system and cables do not show abrasions or disruption.
- Check that there are no screws or parts loosened.

BELT TENSION

WARNING: CARRY OUT THE OPERATIONS WITH THE ENGINE SWITCHED OFF AND COOLED DOWN

During operation, the belt is under strain and wear and as result, lengthening occurs, which could lead to sliding on the pulleys, with a subsequent decrease in the general engine performance.

To restore the proper tension, loosen the screw M8 on the foot of the engine which fastens the pulley can, turn screw M8 (n°32) anti-clock wise using force of 1.8 Kgm and then re-tighten screw M8.

INTERVENTIONS EVERY 20 HOURS

- Clean filter carburetor
- Clean fuel filter
- Check the belt tension and condition
- Lubricate the ball joint of the muffler

INTERVENTIONS EVERY 60 HOURS

- Replace the engine and exhaust silent blocks
- Replace the transmission belt
- Check the status of the intake manifold rubber
- Replace the exhaust pipe sound-absorbent material
- Check the electrode gap spark-plug: if it is over 0.6 mm, change the spark plug
- Rubber components such as belt transmission, silent block, intake manifold and depression tube may be damaged by atmospheric agents. Their durability can therefore be different from what is reported, you should therefore check their condition and provide a possible replacement even outside the agreed time.

INTERVENTIONS EVERY 200 HOURS

- Replace all the bearings (N°41 + N°35)
- Replace all oil seals (N°40)
- Check the internal parts of the engine and carry out their replacement in case the height limit confirm it is necessary.
- Cylinder:
 - must not show signs of seizure or scratches on the filling material (nickel silicon);
 - check the wear of the cylinder in the four points (shown in diagram 1) on X and Y axles, none of the heights obtained must exceed the height limits:

SELECTION A: 66.430mm

SELECTION B: 66.440mm

SELECTION C: 66.450mm

SELECTION D: 66.460mm

The selection reference is stamped on the bottom of the cylinder

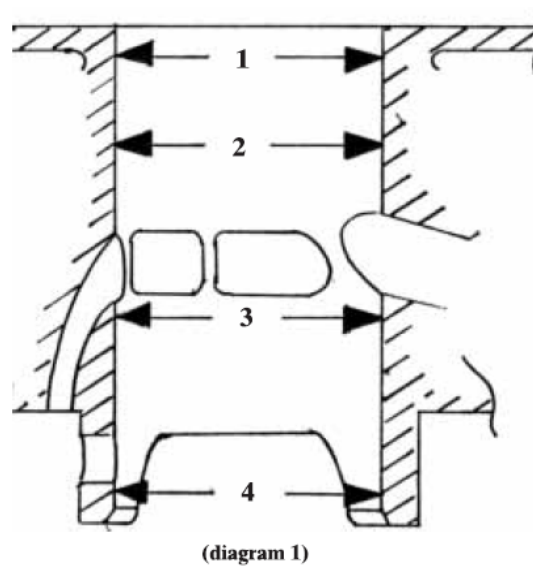

• piston:

- There must not be any signs of seizure or deep cracks.
- Check the wear by measuring the piston at 18.5mm from the bottom keeping the measuring instrument at right angles to the axis pin.

Height limits:

SELECTION A: 66.290mm

SELECTION B: 66.300mm

SELECTION C: 66.310mm

SELECTION D: 66.320mm

- The pin must not be blue because that indicates a high working temperature and the external diameter must not be less than 15.990mm.
- Measure the slack between the piston ring and its seat: slack height limit 0.8mm.
- Piston ring: insert a piston ring in the cylinder one by one, by using the piston, so it is a square, measure the gap that is created between the two ends of piston ring using feeler gauge. Height limit: 0.5mm
- Crankshaft: supporting the crankshaft at the two working points of oil seals, with

two comparators, measure the centering at the two working points of the bearings, marked on diagram 2 with the letter A. Height limit: 0.05mm

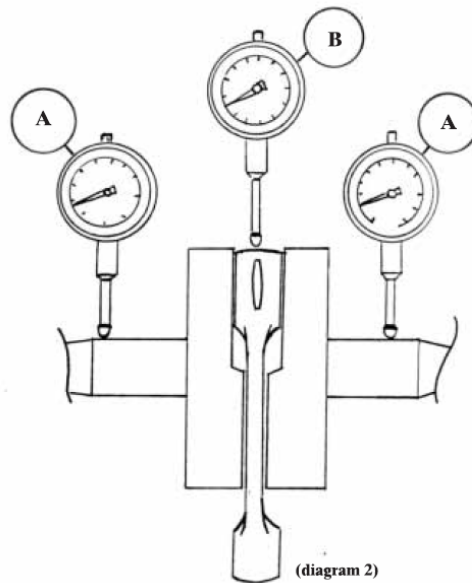

- Measure the bearing seating, which must not be lower than the height limit: 24.98mm
- Check with a feeler gauge that the axle slack of the connecting-rod between the two semi shaft, which must not exceed the height limit: 0.6mm
- Check the radial slack of the connecting rod on the coupling axle which must not exceed the height limit: 0.05mm. This is detected by placing a comparator (B), as shown in diagram 2, and moving the connecting rod vertically. The slack shown by the comparator is assessed. Measure the diameter of the hole in the connecting-rod foot. Height limit: 20.00mm
- Reed valve: Verify that between the frame and the reeds there is no space (diagram 3). Height limit: 0.2mm.

WARNING: The reeds should not and cannot be turned (diagram 4)

(diagram 3)

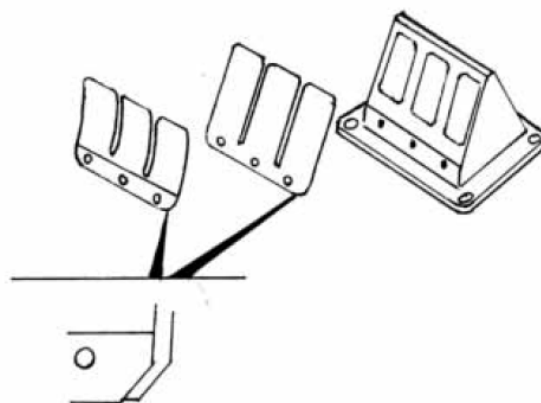
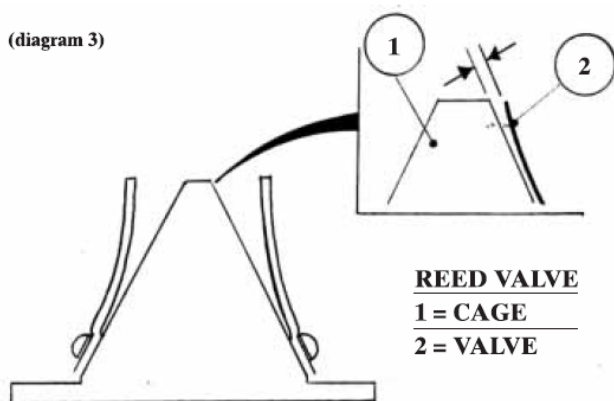

(diagram 4)

TEMPERATURE

The MINI 2 PLUS has been designed to work under certain operating temperatures: so please stick strictly as written.

Temperatures that must not be exceeded when cruising or when the engine is at a fixed rpm for a long time:

- Exhaust gas temperature 580° C.
- Temperature under spark plug 170° C.

Temperatures that must not be exceeded when taking off or when all the power is required to the engine:

- Exhaust gas temperature 600° C.
- Temperature under spark plug 200° C.

WARNING engine will **NEVER**, at any time and condition, exceed:

- 600 ° C temperature of the exhaust gas.
- 200 ° C temperature under spark plug

It therefore makes it appropriate to adopt an instrument that detects these temperatures for the protection of the engine, but especially for your and others' safety.

We also inform you that high exhaust gas temperatures, in many cases, are a symptom of poor carburetion. While high temperatures under the spark plugs, usually, are due to poor ventilation (heat dissipation) of the engine, caused by the presence of bodies and / or materials that prevent the passage of air cooling.

COMPONENTS AND TOOLS ON REQUEST

To have the possibility to customize the engine and then adapt it to different needs and methods of use, SIMONINI offers a range of components on request:

§ **PINION**

In different diameters (57/56/55/53/44) as well as providing the proper reduction ratio, can be used to soften or make more rapid rise in engine speed or to move, maintaining the propeller revolutions, any points of the torque curve that does not meet your needs at a specified "range" of use, as when cruising.

Code MINI2PLUS/51 mm. 57

Code MINI2PLUS/51 mm. 56

Code MINI2PLUS/51 mm. 55

Code MINI2PLUS/51 mm. 53

Code MINI2PLUS/51 mm. 44

§ **PROPELLERS**

We propose a 2-blade wooden propeller

Code E02 cm. 130

§ **MAINTENANCE TOOLS**

To facilitate maintenance operations, we propose

code U01: pinion extractor for d. 53/55/56/57mm

code U02: fly-wheel extractor and pinion extractor for d.44mm

REQUEST FOR REPAIR OR REPLACEMENT OF WARRANTED

ATTENTION

The warranty is valid for 12 months from date of purchase and it covers all the engine parts. It does not include the parts subject to wear: cylinder Nikasil, piston and drive belts. There is NO warranty if the engine is tampered or if any not original parts has been fitted without our approval.

In the case you need, please send the engine to

SIMONINI RACING srl

indicating:

- name
- address
- number of motor
- date of first start
- hours of operation
- any previous repairs
- carburetion setting
- complete description of the problem

Thank you for your trust and we remind you that the staff of SIMONINI RACING srl will be at your disposal for any questions.

SIMONINI RACING SRL

Via per Marano 4303, Loc. San Dalmazio - 41028 Serramazzoni (Mo)

Tel 0536/953005 Fax 0536/953006.

Http: www.Simonini-flying.com

E-mail: info@simonini-flying.com

